



GS Department

Ll. Miralles



Ll. Miralles. GS Dpt.
Head

October 5th 2015

Fundamental Science

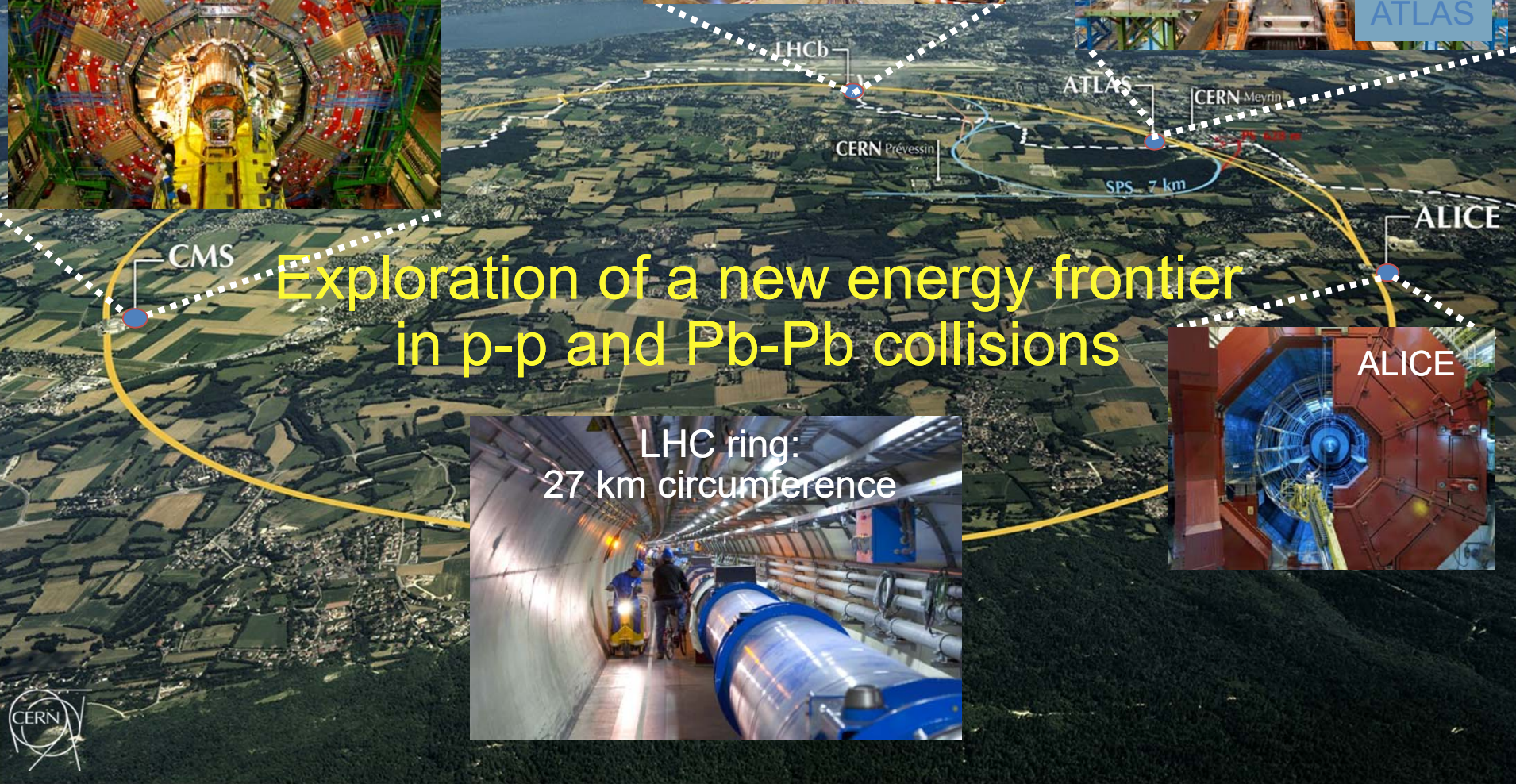
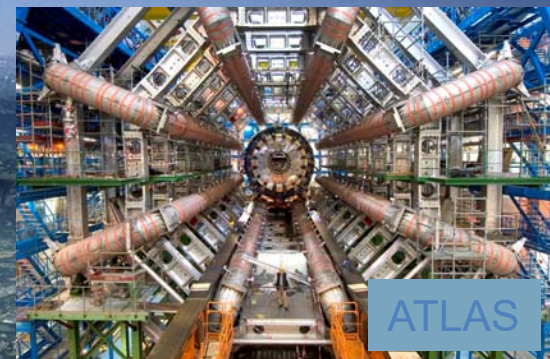

Exploration of a new energy frontier
in p-p and Pb-Pb collisions



- Staff, users, ext. ~ 26 000
- Visits ~ 100 000 en 2014
- Vehicles ~ 22 000
- Site entrances 20
- Entries/day 20 000
- Sites 16
- Site surface ~ 200 Ha
- Fenced perimeter ~ 22 km



- Civil engineering services
- Material Management & Storage Services
- Fire protection services (Fire Brigade)
- Registration, access & safety services
- Facility management services
- Business application services
- Alarm system services
- Mail, Removal & Distribution of Goods Services
- Transport, Shipping & Goods Reception Services
- Waste Management Services
- Person mobility services (Cars, Bicycles, Shuttle ..)
- Library & Archive Services
- Housing & Hotel Services
- Finance & Purchasing Services
- HR Services
- ...



- 495 hotel rooms, 3 restaurants
- 2 main Sites, 657 Buildings, 238 Barracks
- > 15000 active access cards
- > 1000 cars
- > 234000 items at the stores

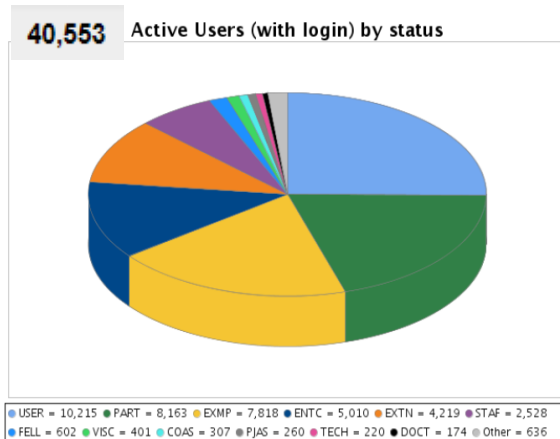

L. Miralles
Head of GS

DDH: C. Delamare

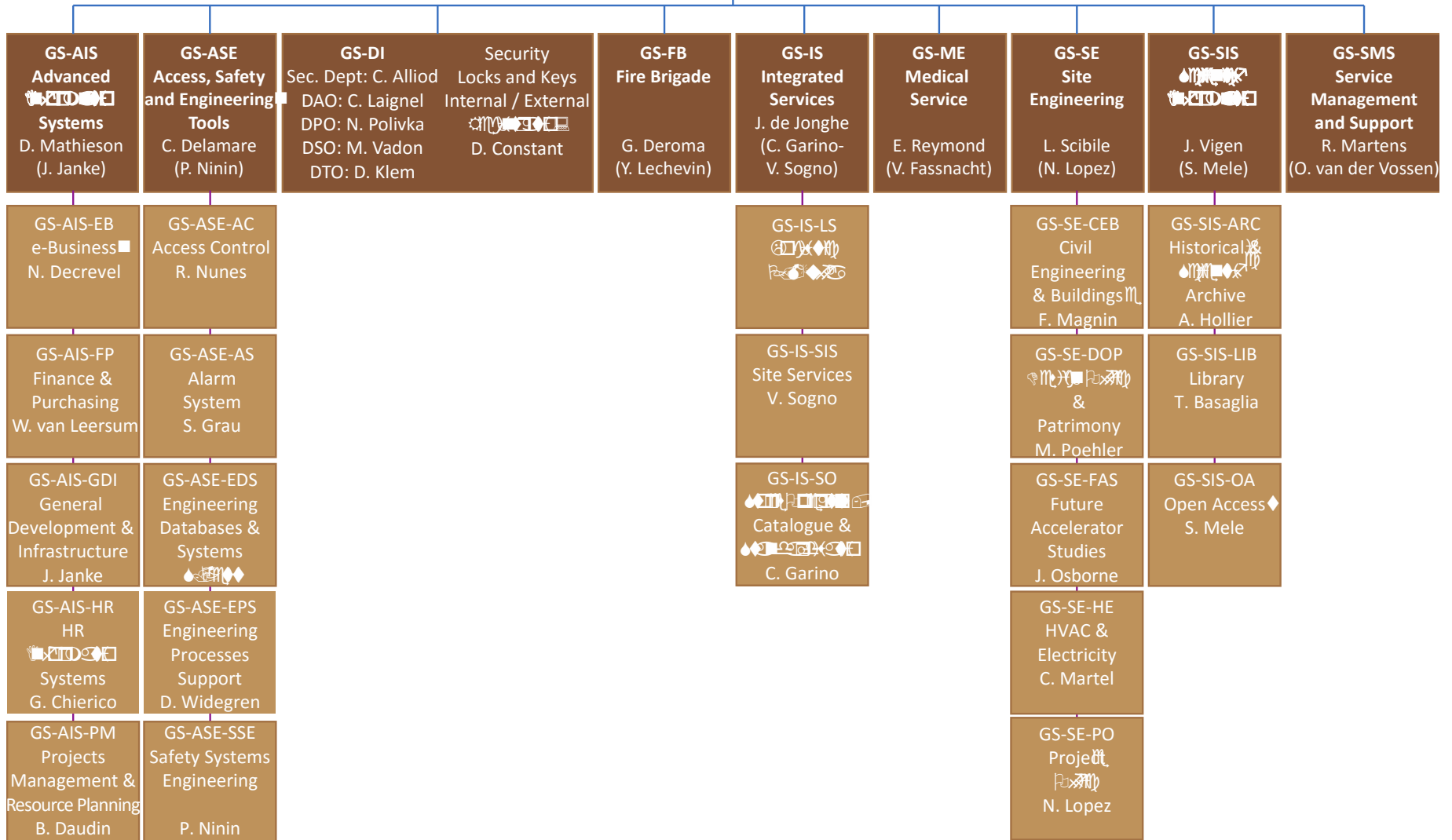

2014 personnel statistics

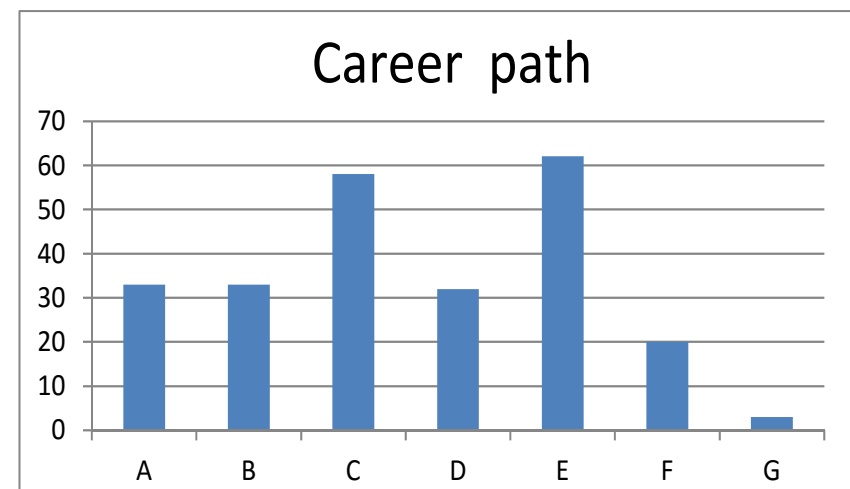
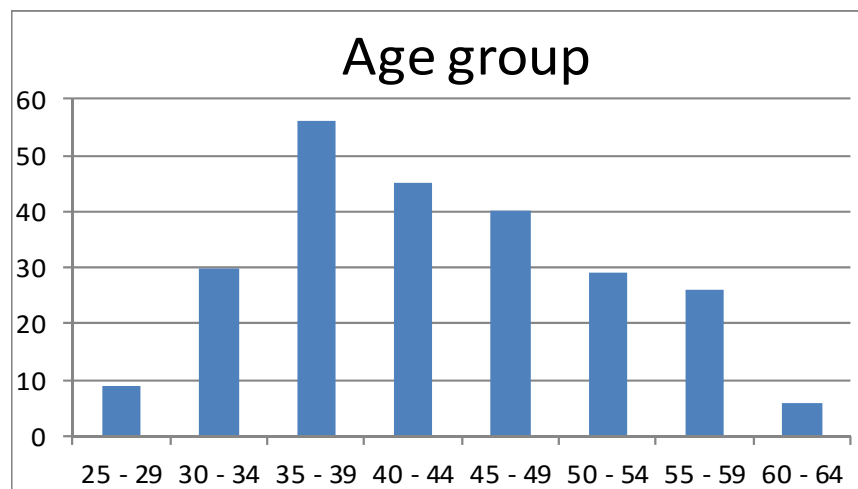
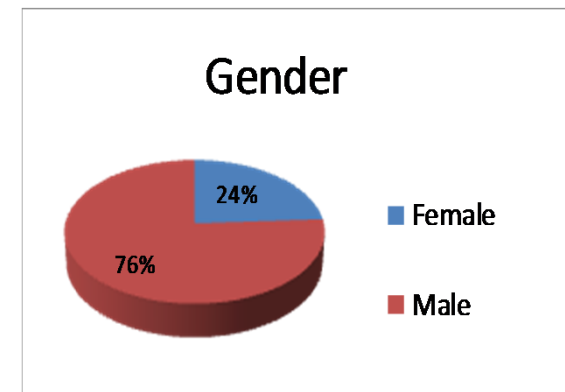
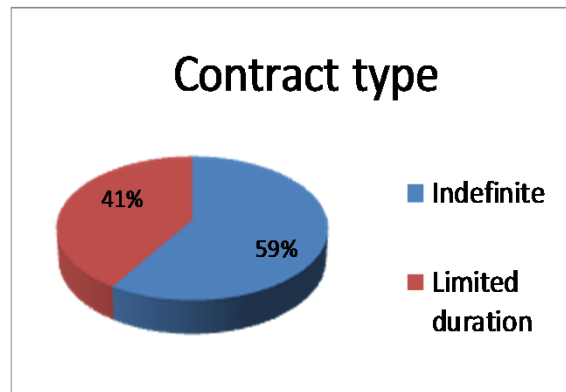
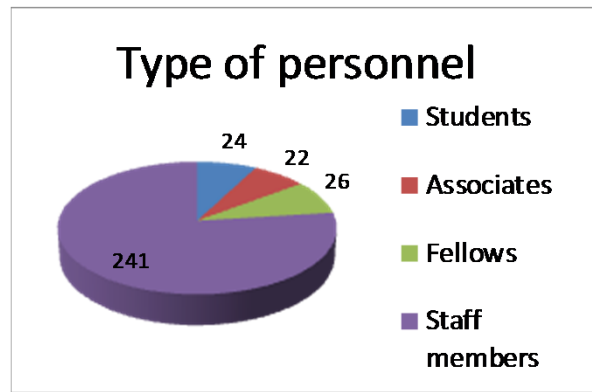

2014 personnel

• Staff	40.2 MCHF
• Fellows	<u>2.3</u> MCHF
	42.5 MCHF

2014 material budget

Work realised in 2014:

- Operation 35.6 MCHF
- Projects 46.9 MCHF



GS Department

Advanced Information Systems

GS-AIS Organization chart

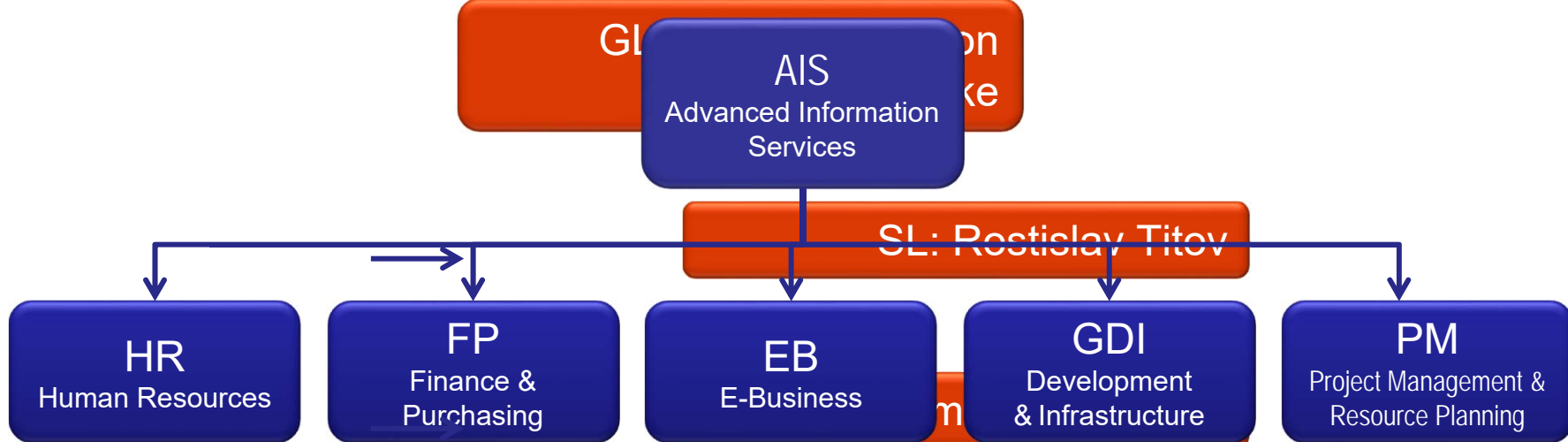

→ **SL: Jan Janke**

→ **SL: Giovanni Chierico**

→ **SL: Benoît Daudin**



Review 2014

- Finance:

- SEPA payments
- Patents Management
- Improved Contract Support
- Software License Manager Tool

- HR:

- PRT for Users' Office
- Payroll Upgrade
- e-RT upgrade

- *e*Personnel File

- Project Start

- EDH:

- New EDH Forms
- Workflow Engine Replacement

- Contract Changes

- Simulations

- IMPACT

- Avis d'Ouverture de Chantier support
- Integration of Fire Permit

- Public Outreach:

- Parallel visit groups
- Automated guide payments
- Ticketing for CERN's 60th anniversary event

- Pension Fund

- Project Start
- Re-implementation of business rules

- EVM for NICA (JINR)

- Application delivered

- Activity Planning Tool (APT)

- New Profit and Loss report

AIS 2014 in Numbers

- HR:
 - 454'700 HRT reports run
 - 9'800 trainings taken
 - 36'570 safety courses passed
 - 52'700 payslips calculated
 - 387 Users' Office Pre-Registrations
- Finance & Logistics:
 - 113'000 CERN Shop sales
 - 2'700 for bookshop sales
 - 15'000 Imports/Exports
 - 176'000 internal transports
- IMPACT:
 - 15'710 coordinated activities
- Public Outreach:
 - 3'960 visits organized
(93'490 visitors)
- Pension Fund:
 - 7'048 pension rights validated.
- Phonebook:
 - 29'000 entries
 - 2.1 million searches
- eGroups
 - 38'400 groups
 - 1.8 million memberships
- EDH:
 - 17'849 users
 - 360'713 document created
 - 759'733 electronic signatures
- CERN Hostel:
 - 32'309 Online reservations



AIS Support Activities in 2014

- Over 6,900 tickets answered (excluding password reset)

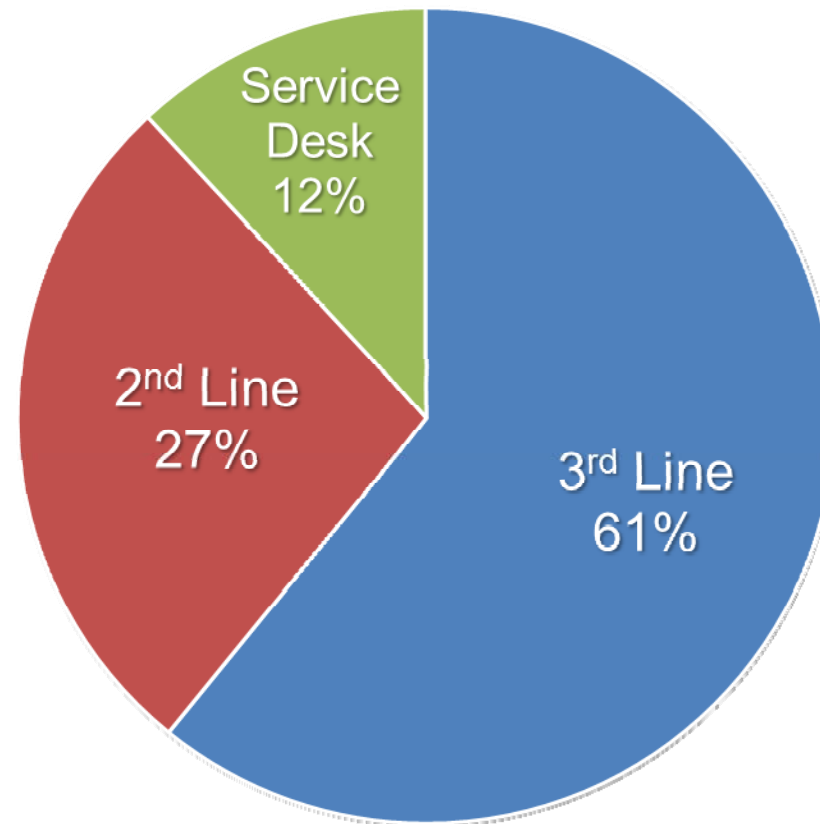

Support ticket closure by service



GS Department

Access, Safety, Engineering tools



PS Access Project

- Major change & success
- Operational since mid-2014
- Full renovation of 14 zones
 - 22 Access points
 - Buildings, buffer zones, doors & grids
 - Interlocks
- 2015
 - Finalization of the CTF zone
 - Integration of Medicis

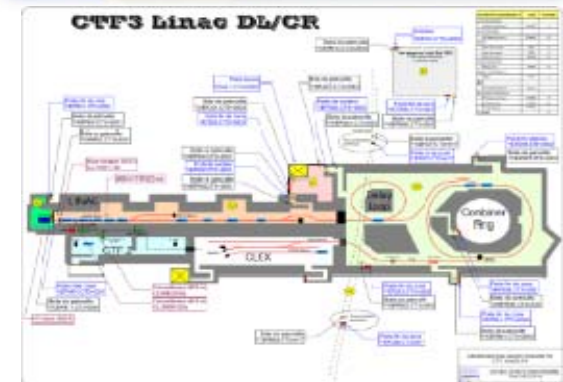

SPS Access

- 2014
 - Operation & Maintenance
 - AWAKE
 - North Hall Ion Beam
 - Installation and Commissioning of a new safety system
- 2015+
 - SPS Access
 - Full system upgrade during LS2
 - Starting now: specification, tendering, contract, test platform; 3D scan; ...

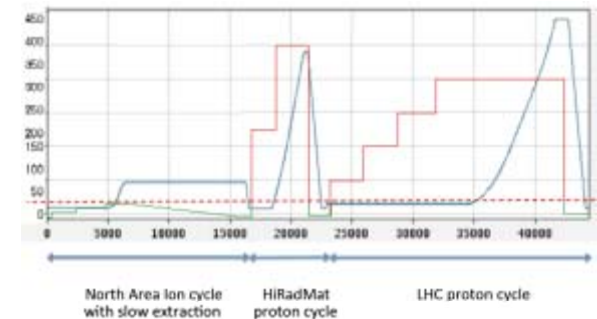
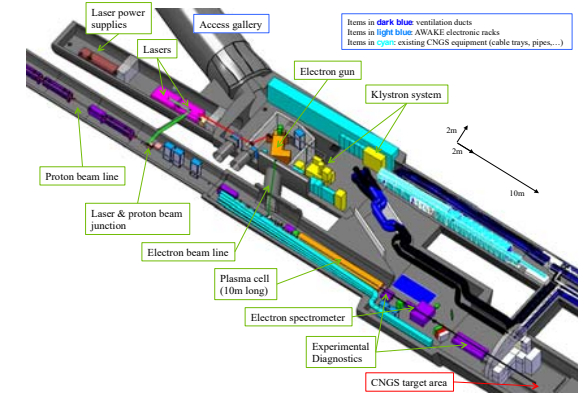

Site Access

- Continuous growth
 - Badge readers and doors (bld 33)
 - Video-surveillance
 - Electronic locks/cylinders
 - Key cabinets
 - Plate recognition (Inter-Site Tunnel; Globe)
 - Site entrances (Prévessin – Rte Maroc)
- Highlights 2015
 - Heating plant (bld 200)
 - ISR (RWTC); SM18
 - ADaMS v.3 to handle access rights
 - Site Protection Project
 - Consistent with the new CERN access policy
 - And many other requests ...



Alarm Systems

Fire detection
 Flammable gas detection
 Oxygen Deficiency Hazard
 Evacuation
 Red telephones
 Alarm transmission

- Alarm systems operational 24/24 during the LS1
 - Strong collaboration with GS/FB
- Continuous growth of the installations
- Preventive maintenance is mandatory
 - Prepare for the 18 months ~non-stop run
 - Continuous improvement of the Infor EAM data
- Policy of regular renovation of installations
 - Major replacement of smoke detectors in 2014
 - Linear smoke detectors in the future
 - Important centrals renewals ongoing in Meyrin & Preveessin before LS2
 - Major renovation of LHC centrals to be performed in LS2 & LS3 – underground and surface – 52 centrals concerned
- Alarm Transmission (CSAM-CHAMN)
 - SCADA transparent upgrade (PCVue) done in 2014
 - Analysis of the causes of the evacuations
 - On-going replacement of main PLC concentrator and Text Displays
 - Transmission of smoke detection analog values
 - Preparation of the next generation
 - Reviewing user requirements

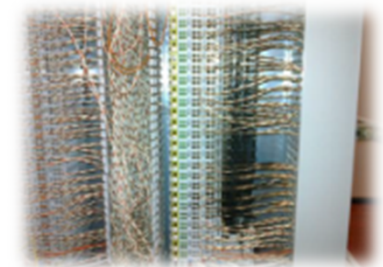
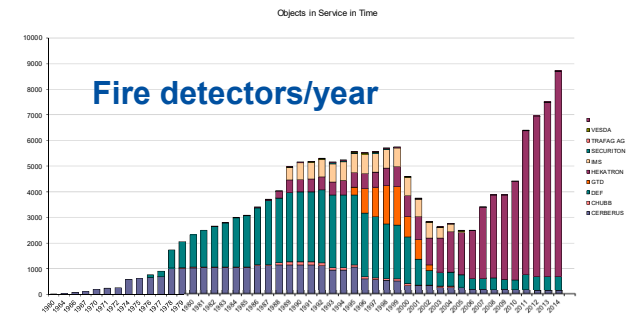

Alarm Systems

Fire detection
Flammable gas detection
Oxygen Deficiency Hazard
Evacuation
Red telephones
Alarm transmission

- Fire Detection and Evacuation
 - Bld 774, HIE-Isolde, ELENA, 772, ME59
 - PS Beam Imminent Warning/Evac
 - Numerous LS1 activities
 - R2E activities LHC7 & LHC5; PS Fire doors
 - Triggering of the LHC evacuation by the Fire detection
 - 2015
 - CTF Evacuation & Beam Imminent Warning
 - Medicis, AWAKE, RWTC, CENF, ...
 - Prepare LS2 (especially SPS Fire protection)
 - Investigate the Global Emergency Evacuation System
- Flammable Gas and ODH Detection
 - Centrals Point 1 & 5; HIE-Isolde
 - Flammable gas detection by air sampling in UX15
 - New technology at CERN
 - ODH sensors non accessible – solutions deployed
 - ODH portable detectors now mandatory to access the LHC
 - 300 detectors bought
 - 2015
 - 300 detectors to maintain
 - GIF++
 - new gas detection solutions for small & big installation under prototyping



CAD Support

- Continuous and significant support effort
 - >1'200 support tickets and 80 new users in 2014
 - IT infrastructure migrations
- Continuous improvement projects
 - Consolidation of the Smarteam Infrastructure
 - Remake of item profile cards
 - Accelerator layout generation (DMU) with EN
- New: CAD dashboard - Very positive feedback
 - Streamlines common end user task + management overview
 - 2014-2015: CAD data outside CERN design offices
 - Analysis and benchmark of 3D viewers
 - Data Exchange (e.g. HL-LHC project)
- 2015 Highlights
 - (Q1): Major change of lifecycle 2D-3D → Support load
 - Continued Smarteam Infrastructure consolidation
 - Develop new drawing management tools
- 2014-2020: Prepare the succession of CATIA V5

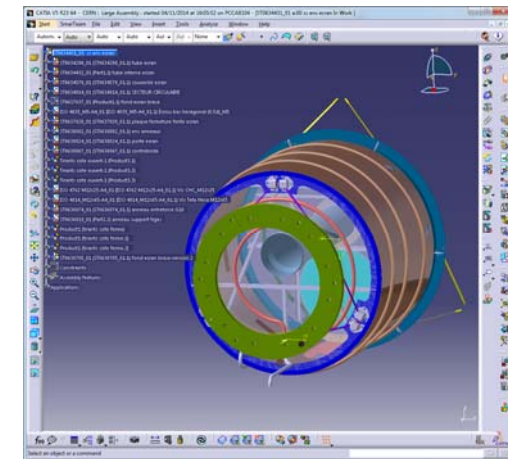
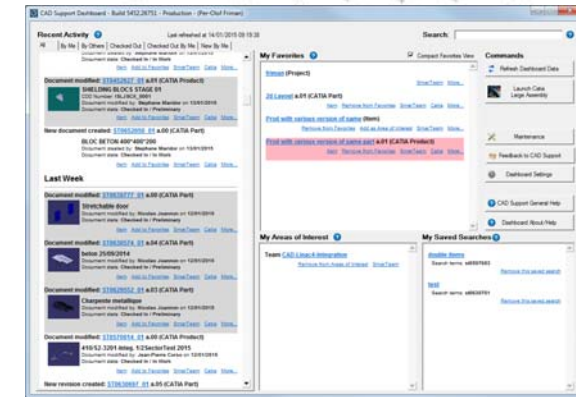
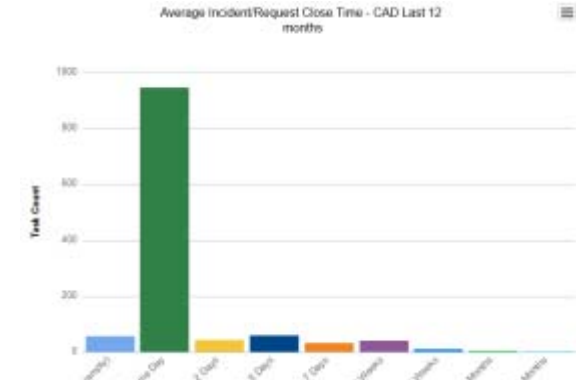

Asset & Maintenance Management

- Pursue the efforts with the A&T sector (Maintenance Management Project)
 - Asset inventory; Work Interventions; Documentation; Spare parts
 - Number of groups using Infor EAM has doubled last 2 years.
 - Sustainable resources and steering to identify
- Major on-going effort and results in GS (SE, FB, IS, ASE)
- Continuous improvement
 - Integrations with Service Desk, CCC-TI, GIS Portal, Baan, ...
 - Upgrade to Infor EAM 11, new import tools, etc.
- In the 2015 pipeline
 - Reporting & Business Intelligence
 - Better granularity of Access rights (“Departmental Security”)
 - Contract Management Module (Automate/facilitate invoicing)
 - SCADA integrations to automate meter readings & inspections
 - TREC evolutions
 - Radioactive Waste Management
 - Property Plant & Equipment Project



- [-] S-JS-10 - BUILDING INFORMATION
 - [-] S-JS-10-DOCUMENTATION-10 - DOCUMENTATION GENERALE
 - [-] S-JS-10-PLANS-10 - PLANS
 - [-] S-FS-10-RESEAU-CHALEUR-10 - RESEAU CHALEUR
 - [-] S-FS-10-AIRCOMP-10 - AIR COMPRIE
 - [-] S-FS-10-CHAUFFAGE-10 - CHAUFFAGE
 - [-] S-FS-10-DISTRIBUTION-GAZ-10 - DISTRIBUTION GAZ
 - [-] S-FS-10-INCENDIE-10 - RESEAU EXTINCTION INCENDIE
 - [-] S-FS-10-MULTI-TECHNIQUE-10 - MULTI TECHNIQUE HVAC
 - [-] S-FS-10-REFROIDISSEMENT-10 - REFRROIDISSEMENT
 - [-] S-FS-10-VENTILATION-10 - VENTILATION
 - [-] S-FS-10-SANITAIRE-10 - SANITAIRE
 - [-] S-ES-10-ELECTRICITE-10 - ELECTRICITE
 - [-] S-FS-10-RESTAURATION-10 - RESTAURATION
 - [-] S-KS-10-AMENAGEMENT-INT-10 - AMENAGEMENT INTERIEUR
 - [-] S-KS-10-CHARPENTE-METAL-10 - CHARPENTE METALLIQUE
 - [-] S-KS-10-ESCALIER-10 - ESCALIER
 - [-] S-KS-10-EVACUATION-10 - EVACUATION
 - [-] S-KS-10-FACADE-10 - FACADE
 - [-] S-KS-10-FENETRE-10 - FENETRES
 - [-] S-KS-10-MUR-10 - MUR
 - [-] S-KS-10-PLAFOND-10 - PLAFOND
 - [-] S-KS-10-PORTE-10 - PORTE



GS Department
Integrated Services

Storage areas (Conventional)

- Around 11'000m² of covered and open storage areas: many recent improvements.



Waste

Additional waste produced during LS1, generating extra disposal costs.

DG-IA 12-R2 | Audit of Waste Management

- Conventional and hazardous waste :
Formalize objectives and strategy



Shipping/Reception/Distribution

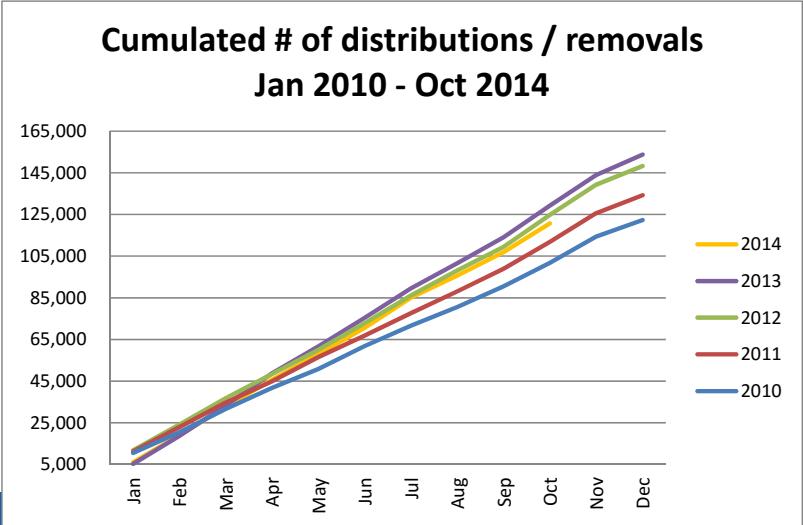
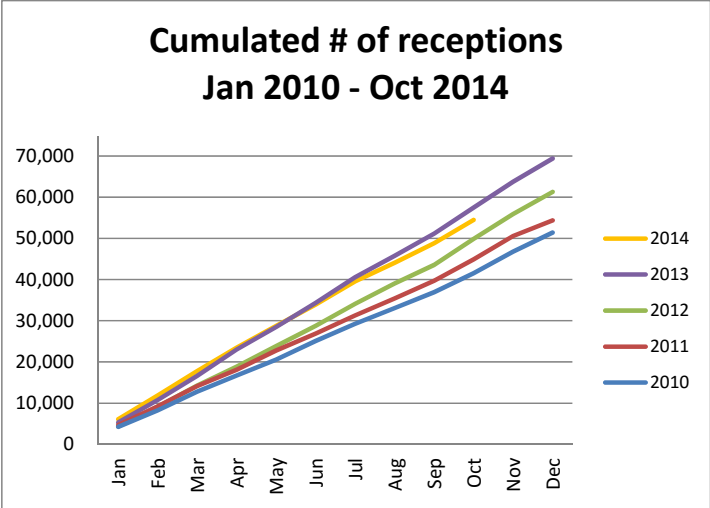
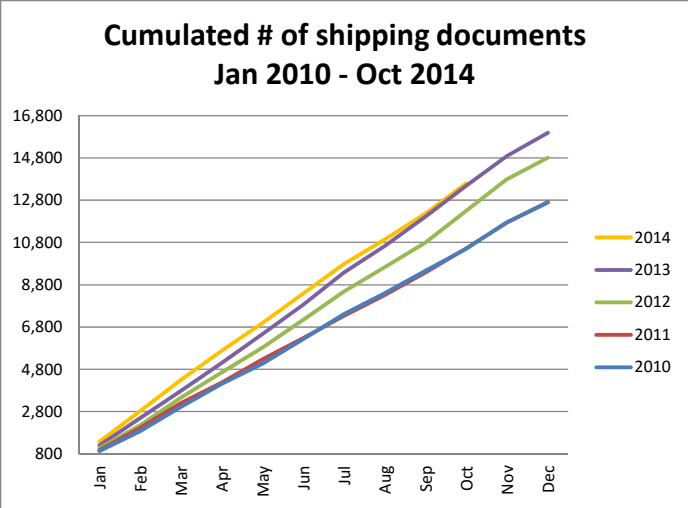

Cleaning

LS1 cleaning activities include:

- Barracks / Bases de vie
- Tunnels and experimental caverns

Lessons learned for LS2:

- Cleaning methods to be reviewed to avoid dust in the tunnels (action: GS)
- Search for vacuum cleaners that are adapted for work in controlled areas (RP)



New Buildings (774)

Mobility: Car-Pool: towards a new model

Two axes to improve usage:

- Increased Sharing
- Rental for Shorter Durations

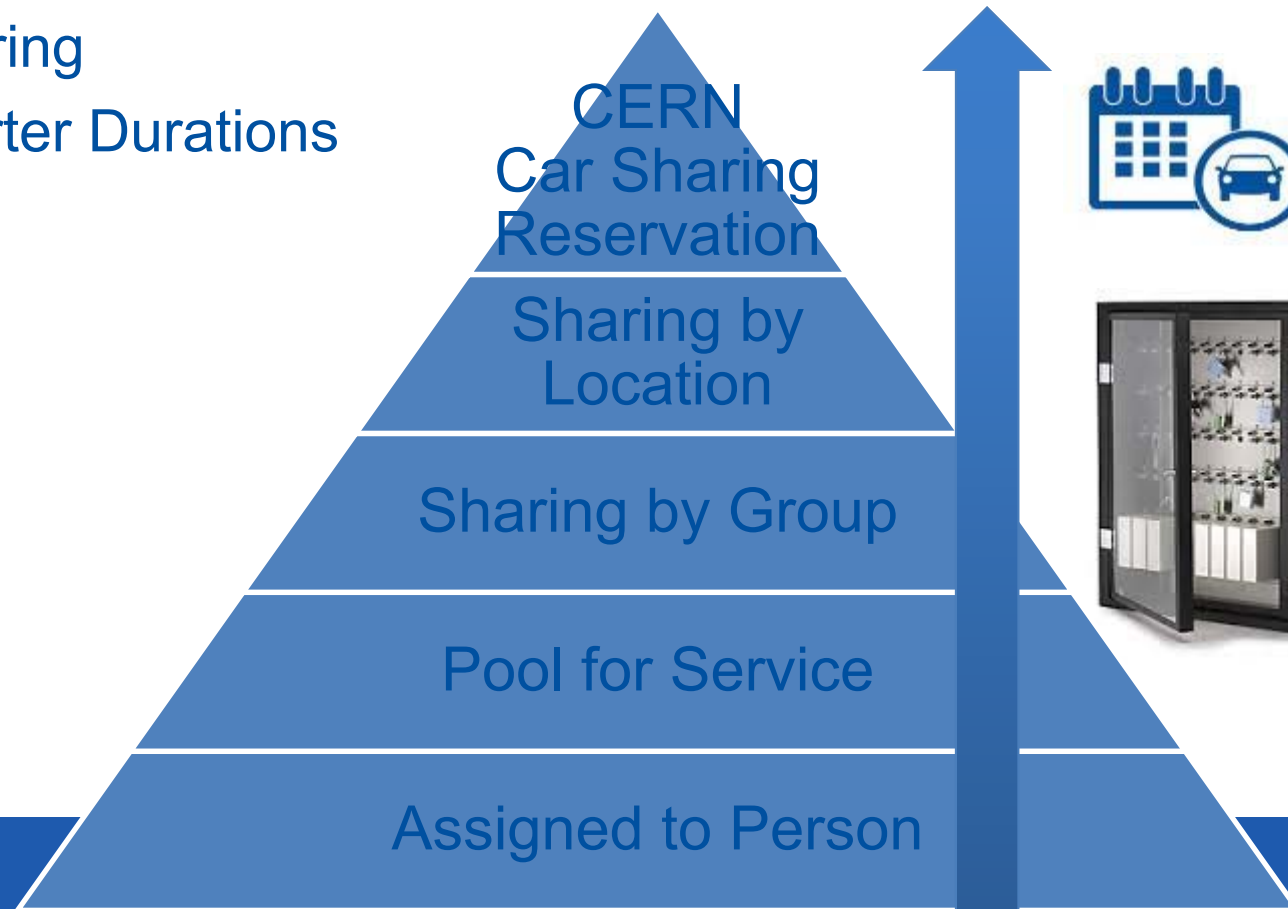

Integrated Mobility

 Car sharing CERN



 Shuttle service CERN



Stores

- LS1 generated a turnover increase (similar pattern as other activities within the group)

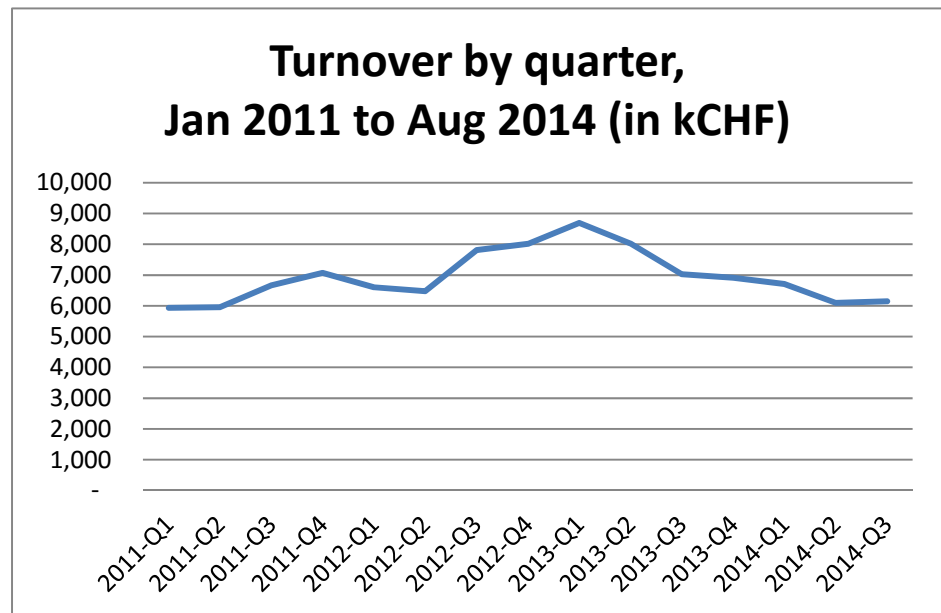
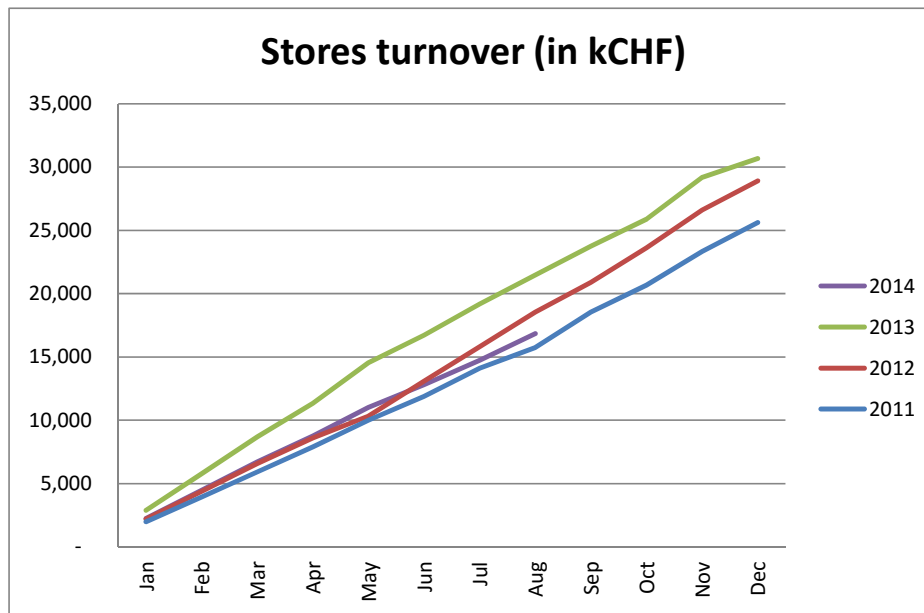

STORES

- Supply of equipment for open days
(264 000 items , Computers, Safety-Cloths, T-Shirts , Hoodies, Pens...)
- Modernization of equipment in Row materiel store (Saw and hydraulic Shears)

Stores: Activity

Last 12 months (27 October 2014)



- Items: 18,687
- Demands: 101,521
- Turnover: 17.7M
- Stock value: 8.8M
- Supplier orders: 13,321

Hotels

- Multi-year investment planning: room renovation, painting and flooring in common spaces, lighting, ventilation,...

- Works staged to maintain hotel capacity (& revenues)

- GS-SE support is needed

		2015	2016	2017	2018	2019	2020	2021	2022
B41							0	1	2/3
B39		0/1	2/3	4	0	32	28	24	8
		0/1	2	3/4	0	0/1	2	3	4
B38		60	30	29	29				
		4/5	3	2	1				
		10	5	5	5	26			
		4/5	3	2	1	0			
		4/5	3	2	1	0/-1			
			3	2	1	0			

- Excellence in Contract Procedure Hotel → establish a level playing field for contractors!
- DG-IA/10-R3 | Audit of Housing Fund**
Define the purpose of CERN accommodation activities and set clear and specific operational and financial performance objectives.

Exhibitions

We support industrial exhibitions of all member states



Israel at CERN



France at CERN



GS Department
Site Engineering

GS-SE Mandate

- The GS-SE Group is responsible to provide, to maintain in working conditions including their eventual operation and to renovate..... the civil engineering structures and infrastructures and the technical services for the tertiary and industrial part of the organization.
- The abovementioned responsibilities include all phases from preliminary design to construction management and hand-over of complete structures and infrastructures.

GS-SE scope

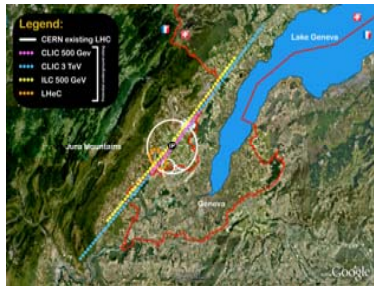

to large projects

COMPLEXITY

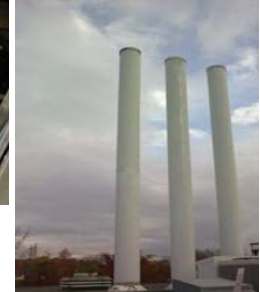

and Operation & Maintenance

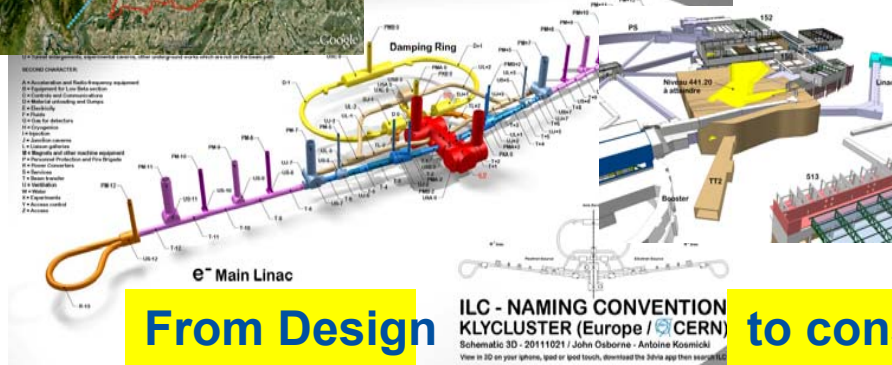

From Design

to construction

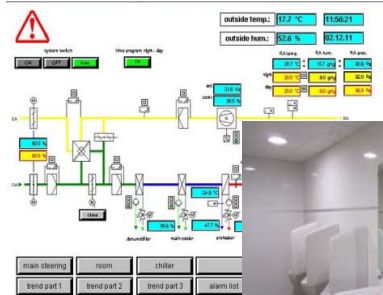

From minor works



GS-SE - Design examples, ELEC and HVAC

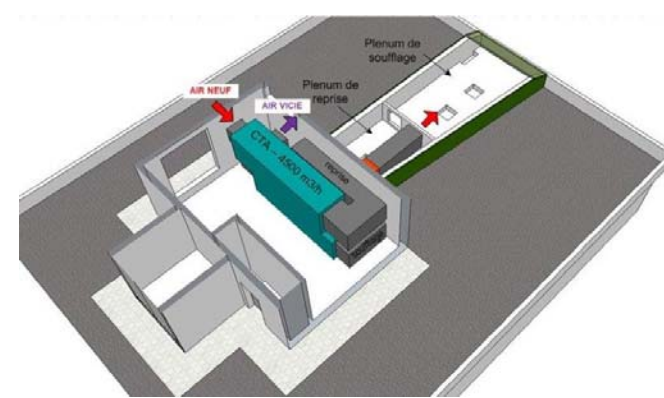
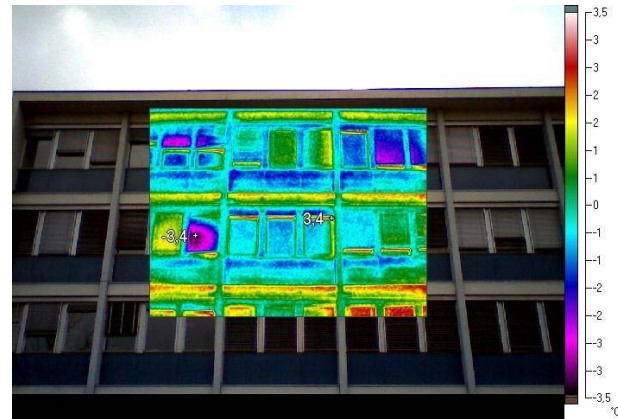
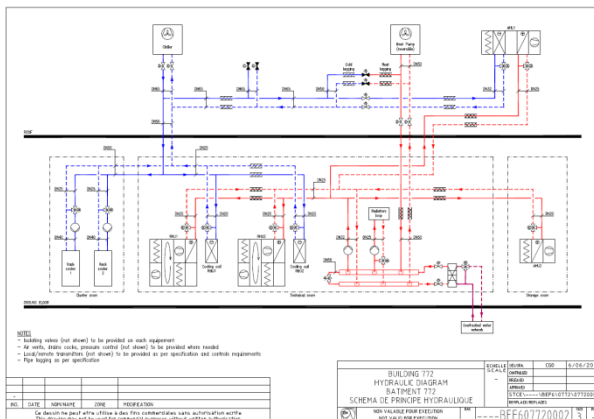
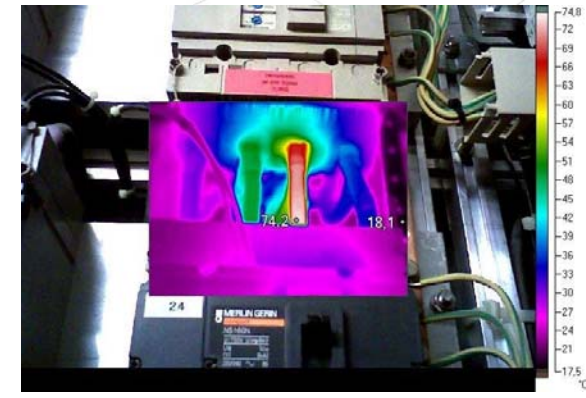
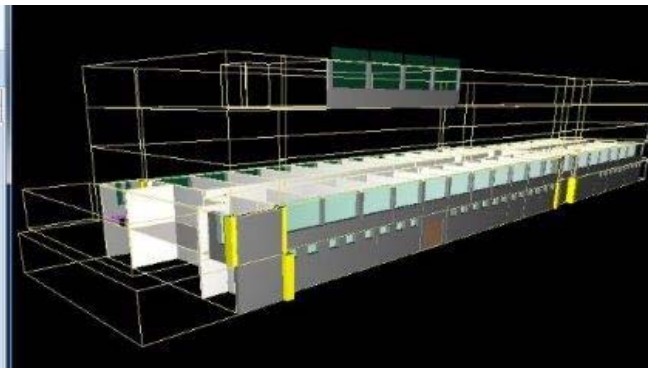
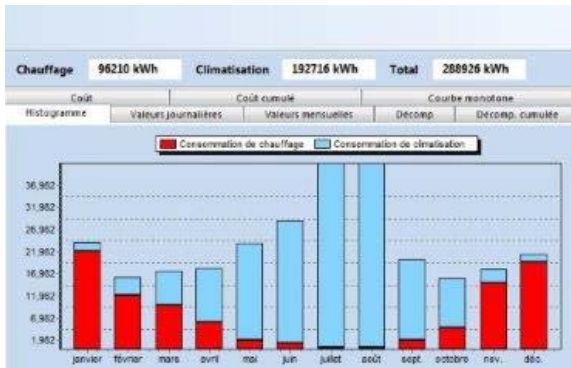
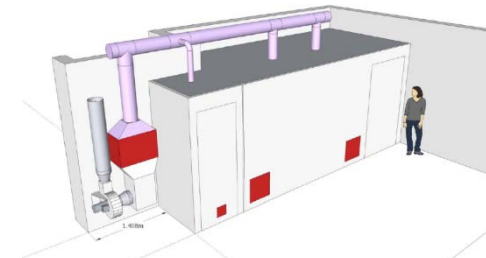

GS-SE works – Charpente metallique



GS-SE works – renovations

BAT 30 - Cafeteria



BAT 31- amphitheatre



BAT 54- conference room



BAT 5- HR

GS-SE works – ISR renovations



New technical room in the ISR



Resin floor for the ISR



Crane rail repairs in the ISR



Painting works for the ISR

GS-SE LS1 works - Carbonation cooling tower PT1



GS-SE LS1 works – PS complex

- B151 PS BRIDGE AIRTIGHTNESS



154 CONCRETE SLABS REPLACEMENT



TT2/TT2A AIRTIGHTNESS



B151 PAINTING

GS-SE project – Bld 107

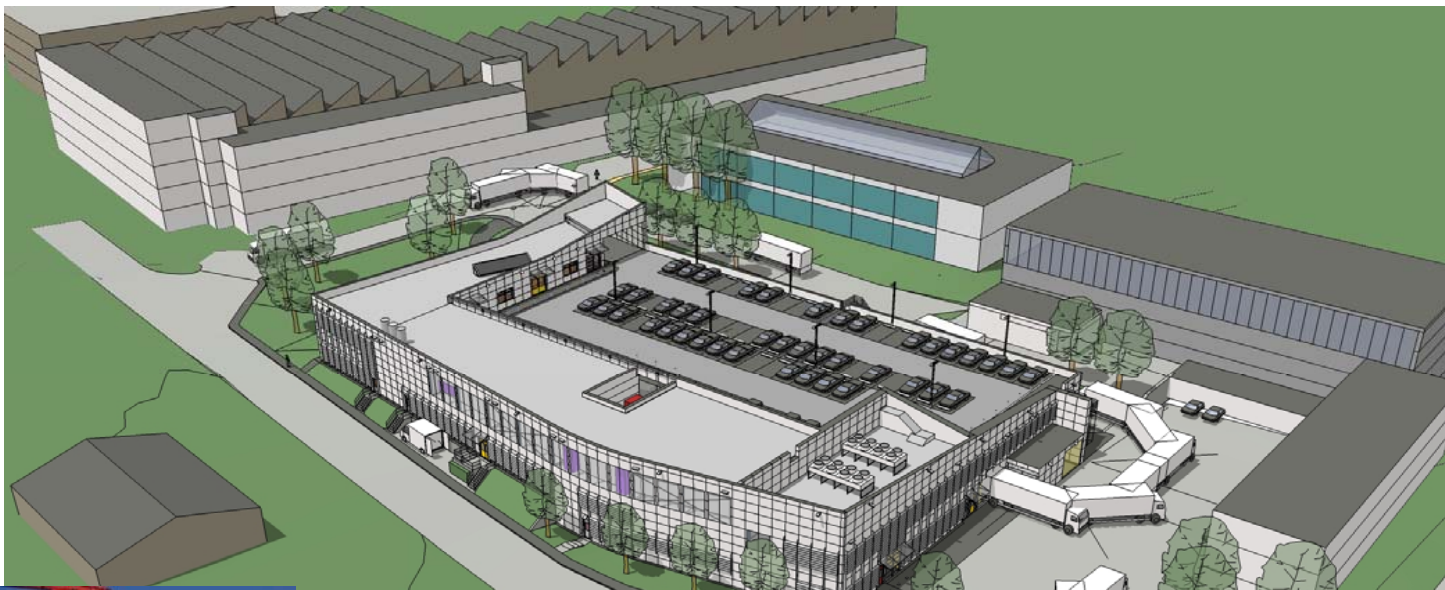

New building 107 – workshops, laboratories and ancillary offices for the TE department.

THANK YOU FOR YOUR
ATTENTION !!

